

# USER MANUAL

GTSM-16V108FUS Series  
GTSM-16V250FUS Series  
GTSM-16V500FUS Series

GTSM-16V200FUS Series  
GTSM-16V330FUS Series  
GTSM-16V830FUS Series



## 1. Introduction

The GTCAP 16V series modules are a complete energy storage module comprised of 6 in series connected individual capacitor cells with nominal capacitance of 650F, 1200F, etc. All cells within the module are individually balanced and protected by a voltage management circuit against overheating and overvoltage. Modules are supplied in a splash water proof housing to avoid water ingress. Temperature monitoring is available with an integrated NTC. All modules are essentially maintenance free.

## 2. Installation

### 2.1 Mechanical

The 16V series modules should be mounted with the bottom side down and safely secured with 4 M6 screw bolts.

### 2.2 Electrical

To avoid arcing the energy storage module must be in a discharged state and the system power must be disconnected during installation. The module is shipped discharged with a shorting wire. The shorting wire must be removed prior to electrical connections.

The positive terminal is a threaded M8 x 1.25 steel bolt. The negative terminal is a threaded M10 x 1.5 steel bolt. Maximum thread depth is 20 mm. Spring washer are required to ensure long term and reliable connections. The connection wires must be of suitable length and diameter. Special attention shall be taken to avoid polarity reversal.

The definition of the terminals are:

No.	Color of wire	Definition	Output level
1	Black	GND	
2	Red	Over voltage alarm	Low level
3	--	Void	
4	Green	Temperature signal	10 kΩ at 25°C

### 2.3 Monitoring

As the following picture, a DC 5V power supply positive can be connected in series with a 1 kΩ resistor. The over voltage alarm is an open collector output. If any cell of the module reports an overvoltage condition the output will be forced to low. See below for a suitable circuit where the LED turns on in case of an overvoltage condition.

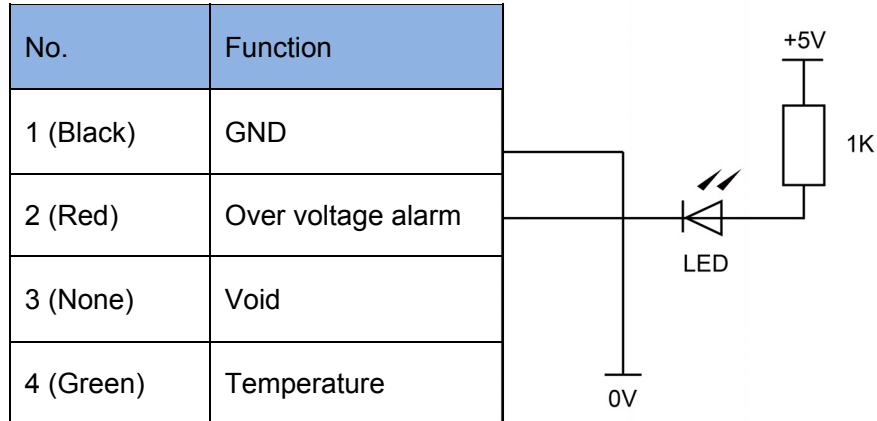

Temperature is measured by a NTC mounted in the center of the module which also corresponds to the temperature hot-spot within the module. At 25°C the resistance of thermistor is 10 kΩ.

### 3. Accessories

The following accessories are provided with each module.

- ✧ 1 x User manual
- ✧ 1 x Shorting wire
- ✧ 1 x Hex head cap, M10x22, Zinc plated screw
- ✧ 1 x Hex head cap, M8x22, Zinc plated screw

### 4. Operation

The module should only be operated within specified voltage and temperature ratings.

Do not reverse polarity.

### 5. Safety and Storage Notice When Application

Do not operate above the absolute maximum voltage to avoid permanent damage.

Do not connect the module to a power supply with wrong polarity.

To avoid electrical shock do not touch module during operation.

For long time charge-discharge cycles with large currents ensure proper ventilation of the module.

Select right wire size base on actual discharge current application.

Please discharge the module completely before installing and/or uninstalling.

### 6 Discharge

6.1 Using a voltmeter, measure the voltage between positive and negative terminal.

6.2 If the voltage is above 2V, a resistor pack (not supplied with the module) shall be connected between the terminals. Proper care needs to be taken in the design and construction of such a dissipative pack. The resistor pack will need to be sized and provided with suitable cooling to handle this power dissipation. Additionally, proper enclosure and packaging is necessary to ensure safety.

6.3 If the voltage is under 2V, connect the shorting wire (already supplied) to the + and – connectors.

6.4 The module is now safe for handling. Leave the shorting wire connected at all times until the module is installed in the system and the power cables are connected.



## 7. Maintenance

Prior to removal from the system, cable removal, or any other handling ensure that the energy storage module is completely discharged in a safe manner. The stored energy and the voltage levels may be lethal if not handled properly. Maintenance should only be conducted by trained personnel on discharged modules.

### 7.1 Routine Maintenance

**7.1.1 Clean exterior surface of dirt/grime:** Use a cleaning cloth dampened with a water/soap solution. Do not use high-pressure sprays or immersion. Keep excess amounts of water away from the PCB cover and power terminals.

**Frequency:** 6 months for outside use, 12 months for inside use (or as needed).

**7.1.2 Check mounting fasteners for proper torque:** Avoid mechanical damage

**Frequency:** 6 months for high vibration environments, 12 months for low vibration environments.

**7.1.3 Inspect housing for signs of damage:** potential internal damage to be identified

**Frequency:** 6 months for outside use, 12 months for inside use (or as needed).

**7.1.4 Check signal/ground connections:** avoid false signals or shock hazards

**Frequency:** 6 months for high vibration environments, 12 months for low vibration environments.

## 8. Storage:

The discharged module can be stored in the original package in a dry place. Discharge an used module prior to stocking or shipment. A shorting wire across the terminals is strongly recommended to ensure the module is discharged at all times.

## 9. Disposal

Do not dispose of module in trash. Dispose of according to local regulations.

